

Three-Phase Alternating Current

Electricity is produced at an electric power plant in the form of *three-phase alternating current*. Three-phase is sometimes written as 3- ϕ . In three-phase alternating current, each phase is displaced from the other two phases by 120 *electrical degrees*. Phase 2 in Fig.A starts its positive alternation 120° after phase 1 but 120° before phase 3.

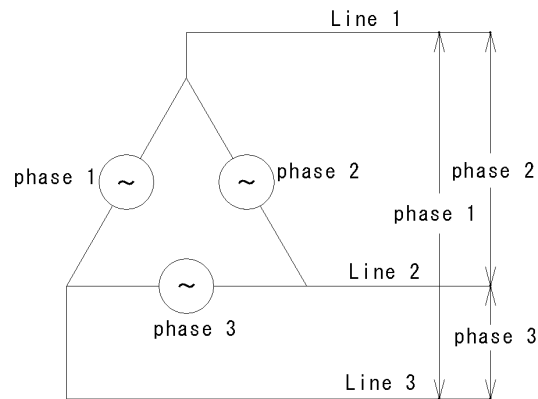

Fig.A Three-phase ac waveform. Each phase is separated by 120 electrical degrees.

Delta connection

A delta connection is shown in Fig B. In this figure, each of the generator symbols represents one of the phases of a three-phase generator. The dot on one end of the generator symbol indicates the reference end of the phase winding.

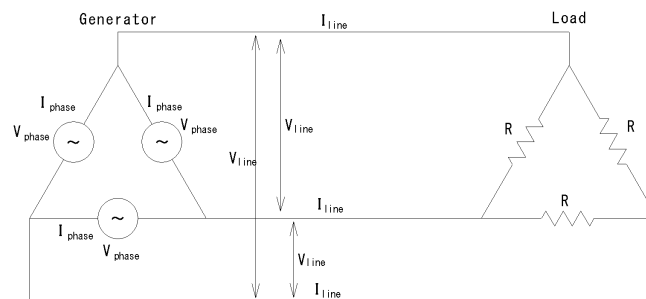

Fig.B Three-phase delta system.

The line voltages and the phase voltage are the same. For a delta connection

$$V_{line} = V_{phase}$$

However, the line currents and the phase currents are not equal. With equal loads connected to each phase, the line current is 1.732 times as great as the phase current. For a delta connection.

$$I_{line} = \sqrt{3}I_{phase}$$

Wye Connection

Figure C shows a wye-connected three-phase generator and load. With the wye-connection and balanced (equal) loads, all currents are the same. For wye-connection

$$I_{line} = I_{phase}$$

However, the line voltages are 1.732 times as great as the phase voltages. For a wye connection.

$$V_{line} = \sqrt{3}V_{phase}$$

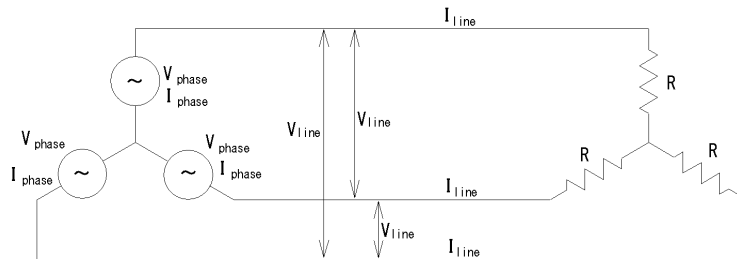

Fig.C Three-phase wye system

Four-Wire Wye System

Fig.D illustrates a four-wire wye system. In this figure, the generator symbol for each phase has been replaced by a coil symbol.

The coil symbol represents one of the phases in a three-phase generator.

The fourth wire of the four-wire system comes from the common center connection of the phase windings. This fourth wire is often called the neutral wire because it is electrically connected to ground (earth). Thus, the fourth wire is neutral (has no voltage) with respect to ground.

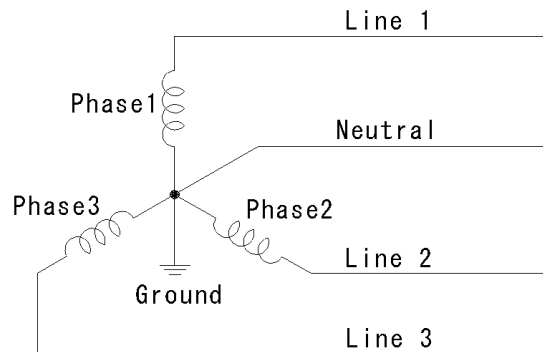

Fig.D Four-wire wye system